

INTERNATIONAL PRODUCT INFORMATION

Rotarix
Rotavirus vaccine
Oral suspension

QUALITATIVE AND QUANTITATIVE COMPOSITION

1 dose (1.5 ml) contains:
Live attenuated human rotavirus RIX4414 strain not less than 10^{6.0} CCID₅₀

The vaccine is a clear and colourless liquid.

CLINICAL INFORMATION

Indications

Rotarix is indicated for the prevention of gastro-enteritis caused by rotavirus (*see sections Warnings and Precautions and Pharmacodynamics*).

Dosage and Administration

Posology

The vaccination course consists of two doses. The first dose may be administered from the age of 6 weeks. There should be an interval of at least 4 weeks between doses. The vaccination course should be completed by the age of 24 weeks.

Rotarix may be given to preterm infants with the same posology (*see sections Adverse Reactions and Pharmacodynamics*).

In clinical trials, spitting or regurgitation of the vaccine has rarely been observed and, under such circumstances, a replacement dose was not given. However, in the unlikely event that an infant spits out or regurgitates most of the vaccine dose, a single replacement dose may be given at the same vaccination visit.

It is strongly recommended that infants who receive a first dose of *Rotarix* complete the 2-dose regimen with *Rotarix*.

Method of administration

Rotarix is for **oral** use only.

ROTARIX SHOULD UNDER NO CIRCUMSTANCES BE INJECTED.

There are no restrictions on the infant's consumption of food or liquid, including breast-milk, either before or after vaccination.

Based on evidence generated in clinical trials, breast-feeding does not reduce the protection against rotavirus gastro-enteritis afforded by *Rotarix*. Therefore, breast-feeding may be continued during the vaccination schedule.

For information on instructions for administration *see section Instructions for Use/Handling*.

Contraindications

Rotarix should not be administered to subjects with known hypersensitivity after previous administration of **Rotarix** vaccine or to any component of the vaccine (*see sections Qualitative and Quantitative Composition and List of Excipients*).

Subjects with history of intussusception.

Subjects with uncorrected congenital malformation (such as Meckel's diverticulum) of the gastrointestinal tract that would predispose to intussusception.

Subjects with Severe Combined Immunodeficiency (SCID) disorder (*see section Adverse Reactions*).

Warnings and Precautions

It is good clinical practice that vaccination should be preceded by a review of the medical history (especially with regard to previous vaccination and possible occurrence of undesirable events) and a clinical examination.

As with other vaccines, administration of **Rotarix** should be postponed in subjects suffering from acute severe febrile illness. However, the presence of a minor infection, such as a cold, should not result in the deferral of vaccination.

The administration of **Rotarix** should be postponed in subjects suffering from diarrhoea or vomiting.

There are no data on the safety and efficacy of **Rotarix** in infants with gastrointestinal illnesses. Administration of **Rotarix** may be considered with caution in such infants when, in the opinion of the physician, withholding the vaccine entails a greater risk.

The risk of intussusception has been evaluated in a large safety trial (including 63,225 infants) conducted in Latin America and Finland. No increased risk of intussusception was observed in this clinical trial following administration of **Rotarix** when compared with placebo.

However, post-marketing safety studies indicate a transient increased incidence of intussusception after vaccination, mostly within 7 days of the first dose and, to a lesser extent, the second dose. The overall incidence of intussusception remains rare. Whether **Rotarix** affects the overall risk of intussusception has not been established.

As a precaution, healthcare professionals should follow-up on any symptoms indicative of intussusception (severe abdominal pain, persistent vomiting, bloody stools, abdominal bloating and/or high fever). Parents/guardians should be advised to promptly report such symptoms.

For subjects with a predisposition for intussusception, *see section Contraindications*.

Administration of **Rotarix** in immunosuppressed infants, including infants on immunosuppressive therapy, should be based on careful consideration of potential benefits and risks (*see section Pharmacodynamics*).

Excretion of the vaccine virus in the stools is known to occur after vaccination and lasts for 10 days on average with peak excretion around the 7th day (*see section Pharmacodynamics*). In clinical trials, cases of transmission of excreted vaccine virus to seronegative contacts of vaccinees have been observed without causing any clinical symptoms. **Rotarix** should be administered with caution to individuals with immunodeficient close contacts, such as individuals with malignancies, or who are otherwise immunocompromised or receiving immunosuppressive therapy. Contacts of recent vaccinees should be advised to observe careful hygiene (including washing their hands) when changing children's nappies.

As with any vaccine, a protective immune response may not be elicited in all vaccinees (*see section Pharmacodynamics*).

The extent of protection that **Rotarix** might provide against rotavirus strains that have not been circulating in clinical trials is currently unknown (*see section Pharmacodynamics*).

Rotarix does not protect against gastro-enteritis due to other pathogens than rotavirus.

ROTARIX SHOULD UNDER NO CIRCUMSTANCES BE INJECTED.

Interactions

Rotarix can be given concomitantly with any of the following monovalent or combination vaccines [including hexavalent vaccines (DTPa-HBV-IPV/Hib)]: diphtheria-tetanus-whole cell pertussis vaccine (DTPw), diphtheria-tetanus-acellular pertussis vaccine (DTPa), *Haemophilus influenzae* type b vaccine (Hib), inactivated polio vaccine (IPV), hepatitis B vaccine (HBV), pneumococcal conjugate vaccine and meningococcal serogroup C conjugate vaccine. Clinical studies demonstrated that the immune responses to and the safety profiles of the administered vaccines were unaffected.

Concomitant administration of **Rotarix** and oral polio vaccine (OPV) does not affect the immune response to the polio antigens. Although concomitant administration of OPV may slightly reduce the immune response to rotavirus vaccine, clinical protection against severe rotavirus gastro-enteritis was shown to be maintained.

Pregnancy and Lactation

Rotarix is not intended for use in adults. Thus human data on use during pregnancy or lactation are not available and animal reproduction studies have not been performed.

Effects on Ability to Drive and Use Machines

Rotarix is not intended for use in adults.

Adverse Reactions

Clinical trial data

The following convention has been used for the classification of frequency:

Very common	$\geq 1/10$
Common	$\geq 1/100$ and $< 1/10$
Uncommon	$\geq 1/1,000$ and $< 1/100$
Rare	$\geq 1/10,000$ and $< 1/1,000$
Very rare	$< 1/10,000$

The safety profile presented below is based on data from clinical trials conducted with either the lyophilised or the liquid formulation of **Rotarix**.

In a total of four clinical trials, approximately 3,800 doses of **Rotarix** liquid formulation were administered to approximately 1,900 infants. Those trials have shown that the safety profile of the liquid formulation is comparable to the lyophilised formulation.

In a total of twenty-three clinical trials, approximately 106,000 doses of **Rotarix** (lyophilised or liquid formulation) were administered to approximately 51,000 infants.

In three placebo-controlled clinical trials, in which **Rotarix** was administered alone (administration of routine paediatric vaccines was staggered), the incidence and severity of

the solicited events (collected 8 days post-vaccination), diarrhoea, vomiting, loss of appetite, fever, irritability and cough/runny nose, were not significantly different in the group receiving **Rotarix** when compared to the group receiving placebo. No increase in the incidence or severity of these events was seen with the second dose.

In a pooled analysis from seventeen placebo-controlled clinical trials including trials in which **Rotarix** was co-administered with routine paediatric vaccines (*see section Interactions*), the following adverse reactions (collected 31 days post-vaccination) were considered as possibly related to vaccination.

Gastrointestinal disorders:

Common: diarrhoea

Uncommon: flatulence, abdominal pain

Skin and subcutaneous tissue disorders

Uncommon: dermatitis

General disorders and administration site conditions

Common: irritability

The risk of intussusception has been evaluated in a large safety trial conducted in Latin America and Finland where 63,225 subjects were enrolled. This trial gave evidence of no increased risk of intussusception in the **Rotarix** group when compared with the placebo group as shown in the table below.

	Rotarix	Placebo	Relative risk (95% CI)
Intussusception within 31 days after administration of:	N=31,673	N=31,552	
First dose	1	2	0.50 (0.07;3.80)
Second dose	5	5	0.99 (0.31;3.21)
Intussusception up to one year of age:	N=10,159	N=10,010	
First dose up to one year of age	4	14	0.28 (0.10;0.81)

CI: confidence interval

Safety in preterm infants

In a clinical study, 1,009 preterm infants were administered **Rotarix** lyophilised formulation or placebo (198 were 27-30 weeks gestational age and 801 were 31-36 weeks gestational age). The first dose was administered from 6 weeks after birth. Serious adverse events were observed in 5.1% of recipients of **Rotarix** as compared to 6.8% of placebo recipients. Similar rates of other adverse events were observed in **Rotarix** and placebo recipients. No cases of intussusception were reported.

Post-marketing data

Gastrointestinal disorders:

Rare: haematochezia, gastroenteritis with vaccine viral shedding in infants with Severe Combined Immunodeficiency (SCID) disorder.

Very rare: intussusception (*see section Warnings and Precautions*).

Overdose

Some cases of overdose have been reported. In general, the adverse event profile reported in these cases was similar to that observed after administration of the recommended dose of Rotarix.

PHARMACOLOGICAL PROPERTIES

Pharmaco-therapeutic group: viral vaccines, ATC code: J07BH01

Pharmacodynamics

Protective efficacy

In clinical trials, efficacy was demonstrated against gastro-enteritis due to rotavirus of the most common genotypes G1P[8], G2P[4], G3P[8], G4P[8] and G9P[8] and against uncommon rotavirus genotypes G8P[4] (severe gastro-enteritis) and G12P[6] (any gastro-enteritis). All of these strains are circulating worldwide.

The protective efficacy of **Rotarix** lyophilised formulation against any and severe rotavirus gastro-enteritis was evaluated in Europe, Latin America, Africa and Asia.

Severity of gastro-enteritis was defined according to two different criteria:

- the Vesikari 20-point scale, which evaluates the full clinical picture of rotavirus gastro-enteritis by taking into account the severity and duration of diarrhoea and vomiting, the severity of fever and dehydration as well as the need for treatment

or

-the clinical case definition based on World Health Organization (WHO) criteria

Protective efficacy in Europe and Latin America

After two doses of **Rotarix**, the protective vaccine efficacy observed in the studies conducted in Europe and Latin America during the first and second year of life combined is presented in table 1 and table 2.

Table 1: Study conducted in Europe: 1st and 2nd year of life combined (Rotarix N=2,572; Placebo N=1,302 (§))

Vaccine efficacy (%) against any and severe rotavirus gastro-enteritis		
[95% CI]		
Strain	Any severity	Severe [†]
G1P[8]	89.5 [82.5;94.1]	96.4 [90.4;99.1]
G2P[4]	58.3 [10.1;81.0]	85.5 [24.0;98.5]
G3P[8]	84.8 [41.0;97.3]	93.7 [52.8;99.9]
G4P[8]	83.1 [55.6;94.5]	95.4 [68.3;99.9]
G9P[8]	72.5 [58.6;82.0]	84.7 [71.0;92.4]
Strains with P[8] genotype	81.8 [75.8; 86.5]	91.9 [86.8;95.3]
Circulating rotavirus strains	78.9 [72.7;83.8]	90.4 [85.1;94.1]

Vaccine efficacy (%) against rotavirus gastro-enteritis requiring medical attention [95% CI]	
Circulating rotavirus strains	83.8 [76.8;88.9]
Vaccine efficacy (%) against hospitalisation due to rotavirus gastro-enteritis [95% CI]	
Circulating rotavirus strains	96.0 [83.8;99.5]

† Severe gastro-enteritis was defined as a score ≥ 11 on the Vesikari scale

(§) ATP cohort for efficacy. This includes all subjects from the ATP cohort for safety who have entered into the concerned efficacy follow-up period

Table 2: Study conducted in Latin America: 1st and 2nd year of life combined (Rotarix N=7,205; Placebo N=7,081 (§))

Strain	Vaccine efficacy (%) against severe rotavirus gastro-enteritis[†] [95% CI]
All RVGE	80.5 [71.3; 87.1]
G1P[8]	82.1 [64.6;91.9]
G3P[8]	78.9 [24.5;96.1]
G4P[8]	61.8 [4.1;86.5]
G9P[8]	86.6 [73.0;94.1]
Strains with P[8] genotype	82.2 [73.0;88.6]

† Severe rotavirus gastro-enteritis was defined as an episode of diarrhoea with or without vomiting that required hospitalisation and/or re-hydration therapy in a medical facility (WHO criteria)

(§) ATP cohort for efficacy. This includes all subjects from the ATP cohort for safety who have entered into the concerned efficacy follow-up period

The vaccine efficacy against severe rotavirus gastro-enteritis was 38.6% (95% CI: <0.0;84.2) for G2P[4] strain. The number of cases, on which the estimates of efficacy against G2P[4] were based, were very small.

A pooled analysis of four efficacy studies, showed a 71.4% (95% CI: 20.1;91.1) efficacy against severe gastro-enteritis (Vesikari score ≥ 11) caused by rotavirus G2P[4] strain.

Since the immune response observed after 2 doses of *Rotarix* liquid formulation was comparable to the immune response observed after 2 doses of *Rotarix* lyophilised formulation, the levels of vaccine efficacy observed with the lyophilised formulation can be extrapolated to the liquid formulation.

Protective efficacy in Africa

A clinical study performed in Africa in more than 4,900 subjects evaluated *Rotarix* given at approximately 10 and 14 weeks of age (2 doses) or 6, 10 and 14 weeks of age (3 doses). The vaccine efficacy against severe rotavirus gastro-enteritis during the first year of life was 61.2% (95% CI: 44.0;73.2). The study was not powered to evaluate a difference in vaccine efficacy between the 2- and 3-dose regimens.

The protective vaccine efficacy observed against any and severe rotavirus gastro-enteritis is presented in Table 3.

Table 3: Study conducted in Africa: 1st year of life – pooled results (*Rotarix* N=2,974; Placebo N = 1,443 (§))

Vaccine efficacy (%) against any and severe rotavirus gastro-enteritis [95% CI]		
Strain	Any severity	Severe†
G1P[8]	68.3 (53.6;78.5)	56.6 (11.8;78.8)
G2P[4]	49.3 (4.6;73.0)	83.8 (9.6;98.4)
G3P[8]	43.4* (<0;83.7)	51.5* (<0;96.5)
G8P[4]	38.7* (<0;67.8)	63.6 (5.9;86.5)
G9P[8]	41.8* (<0;72.3)	56.9* (<0;85.5)
G12P[6]	48.0 (9.7;70.0)	55.5* (<0; 82.2)
Strains with P[4] genotype	39.3 (7.7;59.9)	70.9 (37.5;87.0)
Strains with P[6] genotype	46.6 (9.4;68.4)	55.2* (<0;81.3)
Strains with P[8] genotype	61.0 (47.3;71.2)	59.1 (32.8;75.3)

† Severe gastro-enteritis was defined as a score ≥ 11 on the Vesikari scale

(§) ATP cohort for efficacy. This includes all subjects from the ATP cohort for safety who have entered into the concerned efficacy follow-up period

* Not statistically significant ($p \geq 0.05$). These data should be interpreted with caution

Sustained efficacy up to 3 years of age in Asia

A clinical study conducted in Asia (Hong Kong, Singapore and Taiwan) in more than 10,000 subjects evaluated *Rotarix* given according to different schedules (2, 4 months of age; 3, 4 months of age).

After two doses of *Rotarix*, the protective vaccine efficacy observed up to 3 years of age is presented in table 4.

Table 4: Study conducted in Asia: Efficacy up to 2 and 3 years of age (*Rotarix* N=5,263; Placebo N = 5,256 (§))

	Efficacy up to 2 years of age	Efficacy up to 3 years of age
Vaccine efficacy (%) against severe rotavirus gastro-enteritis (95% CI)		
Strain	Severe†	Severe†
G1P[8]	100.0 (80.8;100.0)	100.0 (84.8;100.0)
G2P[4]	100.0* (<0;100.0)	100.0* (<0;100.0)
G3P[8]	94.5 (64.9;99.9)	95.2 (70.4;99.9)
G9P[8]	91.7 (43.8;99.8)	91.7 (43.8;99.8)
Strains with P[8]	95.8	96.6

genotype	(83.8;99.5)	(87.0;99.6)
Circulating rotavirus strains	96.1 (85.1;99.5)	96.9 (88.3;99.6)
Vaccine efficacy (%) against rotavirus gastro-enteritis requiring hospitalisation and/or rehydration therapy in a medical facility [95% CI]		
Circulating rotavirus strains	94.2 (82.2;98.8)	95.5 (86.4;99.1)

† Severe gastro-enteritis was defined as a score ≥ 11 on the Vesikari scale

(§) ATP cohort for efficacy. This includes all subjects from the ATP cohort for safety who have entered into the concerned efficacy follow-up period

* Not statistically significant ($p \geq 0.05$). These data should be interpreted with caution

Immune response

In different clinical studies conducted in Europe, Latin America and Asia, 1,957 infants received **Rotarix** lyophilised formulation and 1,006 infants received a placebo according to different vaccination schedules. The percentage of subjects initially seronegative for rotavirus (IgA antibody titres < 20 U/ml (by ELISA)) with serum anti-rotavirus IgA antibody titers ≥ 20 U/ml one or two months after the second dose of vaccine or placebo ranges from 77.9% to 100% and from 0% to 17.1% respectively.

In three comparative trials, the immune response elicited by **Rotarix** liquid formulation was comparable to the one elicited by **Rotarix** lyophilized formulation.

In a clinical study conducted in Africa, the immune response was evaluated in 332 infants who received **Rotarix** (N=221) or placebo (N=111) according to a 10 and 14 weeks schedule (2 doses) or 6, 10 and 14 weeks schedule (3 doses). The percentage of subjects initially seronegative for rotavirus (IgA antibody titres < 20 U/ml (by ELISA)) with serum anti-rotavirus IgA antibody titers ≥ 20 U/ml one month after the last dose of vaccine or placebo was 58.4% (pooled regimens) and 22.5%, respectively.

Immune response in preterm infants

In a clinical study conducted in preterm infants with the lyophilised formulation, **Rotarix** was immunogenic; 85.7% of subjects achieved serum anti-rotavirus IgA antibody titers ≥ 20 U/ml (by ELISA) one month after the second dose of vaccine.

Safety in infants with human immunodeficiency (HIV) infection

In a clinical study, 100 infants with HIV infection were administered **Rotarix** lyophilised formulation or placebo. The safety profile was similar between **Rotarix** and placebo recipients.

Vaccine shedding

Excretion of the vaccine virus in the stools occurs after vaccination and lasts for 10 days on average with peak excretion around the 7th day. Viral antigen particles detected by ELISA were found in 50% of stools after the first dose and 4% of stools after the second dose. When these stools were tested for the presence of live vaccine strain, 17% were positive.

In two comparative controlled trials, vaccine shedding after vaccination with **Rotarix** liquid formulation was comparable to that observed after vaccination with **Rotarix** lyophilised formulation.

Effectiveness

In observational studies, vaccine effectiveness was demonstrated against severe gastro-enteritis leading to hospitalisation due to rotavirus of common genotypes G1P[8], G2P[4], G3P[8] and G9P[8] as well as the less common rotavirus genotype G9P[4] and G9P[6]. All of these strains are circulating worldwide.

Table 5 shows the results of several matched case-control studies conducted to evaluate the effectiveness of *Rotarix* against severe rotavirus gastro-enteritis leading to hospitalisation.

Table 5: Effectiveness against severe rotavirus gastro-enteritis leading to hospitalisation

Countries	Age	N (cases/ controls)	Effectiveness after 2 doses RV hospitalisation	
			Strain	Effectiveness (%) [95% CI]
High Income Countries				
Belgium	< 4 yrs	160/198	All G1P[8] G2P[4]	90 [81;95] 95 [78;99] 85 [64;94]
	3-11 m		All G2P[4]	91 [75;97] 83 [11;96]
Singapore	< 5 yrs	136/272	All G1P[8]	84 [32;96] 91 [30;99]
Taiwan	< 3 yrs	275/1,623	All G1P[8]	92 [75;98] 95 [69;100]
US	< 2 yrs	85/1,062	All G1P[8] G2P[4]	85 [73;92] 88 [68;95] 88 [68;95]
	8-11 m		All	89 [48;98]
US	< 5 yrs	74/255	G3P[8]	68 [34;85]
Middle Income Countries				
Bolivia	< 3 yrs	300/974	All G9P[8] G3P[8] G2P[4] G9P[6]	77 [65;84]* 85 [69;93] 93 [70;98] 69 [14;89] 87 [19;98]
	6-11 m		All G9P[8]	77 [51;89] 90 [65;97]
Brazil	< 2 yrs	115/1,481	All G1P[8] G2P[4]	72 [44;85]* 89 [78;95] 76 [64;84]
Brazil	< 3 yrs	249/249	All G2P[4]	76 [58;86] 75 [57;86]
	3-11 m		All G2P[4]	96 [68;99] 95 [66;99]
El Salvador	< 2 yrs	251/770	All	76 [64;84]*
	6-11 m			83 [68;91]
Mexico	< 2 yrs	9/17	G9P[4]	94 [16;100]
Low Income Countries				
Malawi	< 2 yrs	81/234	All	63 [23;83]

* In subjects who did not receive the full course of vaccination, the effectiveness after one dose ranged from 51 % (95% CI: 26;67, El Salvador) to 60% (95% CI: 37;75, Brazil).

yr(s): year(s)

m: months

Impact on mortality[§]

Impact studies with **Rotarix** conducted in Panama, Brazil and Mexico showed a decrease in all cause diarrhoea mortality ranging from 22% to 56% in children less than 5 years of age, within 2 to 3 years after vaccine introduction.

Impact on hospitalisation§

In a retrospective database study in Belgium conducted in children 5 years of age and younger, the direct and indirect impact of **Rotarix** vaccination on rotavirus-related hospitalisation ranged from 64% (95% CI: 49;76) to 80% (95% CI: 77;83) two years after vaccine introduction. Similar studies in Brazil, Australia and El Salvador showed a reduction of 45 to 88%.

In addition, two impact studies on all-cause diarrhoea hospitalisation conducted in Latin America showed a reduction of 38 to 40% four years after vaccine introduction.

§NOTE: Impact studies are meant to establish a temporal relationship but not a causal relationship between the disease and vaccination.

Pharmacokinetics

Not relevant for vaccines.

Clinical Studies

See section Pharmacodynamics.

Non-Clinical Information

Preclinical data reveal no special hazard for humans based on conventional studies of repeated dose toxicity.

PHARMACEUTICAL PARTICULARS

List of Excipients

Sucrose, di-sodium adipate, Dulbecco's Modified Eagle Medium (DMEM), sterile water.

Shelf Life

The expiry date is indicated on the label and packaging.

Special Precautions for Storage

Store in a refrigerator (2°C – 8°C). Do not freeze.
Store in the original package in order to protect from light.

The storage conditions are detailed on the packaging.

Nature and Contents of Container

1.5 ml of **oral** suspension in a squeezable tube (LDPE) fitted with a membrane and a cap (polypropylene). Pack sizes of 1, 10 or 50.

Not all presentations are available in every country.

Incompatibilities

This medicinal product must not be mixed with other medicinal products.

Instructions for Use/Handling (see end of the leaflet)

The vaccine is presented as a clear, colourless liquid, free of visible particles, for **oral** administration.

The vaccine is ready to use (no reconstitution or dilution is required).

The vaccine is to be administered **orally** without mixing with any other vaccines or solutions.

The vaccine should be inspected visually for any foreign particulate matter and/or abnormal physical appearance. In the event of either being observed, discard the vaccine.

Any unused vaccine or waste material should be disposed of in accordance with local requirements.

Instructions for administration of the vaccine:

Please read the instructions for use all the way through before starting to give the vaccine.

A What you need to do before giving Rotarix

- Check the expiry date.
- Check the tube has not been damaged nor is already open.
- Check the liquid is clear and colourless, without any particles in it.

If you notice anything abnormal, do not use the vaccine.

- This vaccine is given orally - straight from the tube.
- It is ready to use - you do not need to mix it with anything.

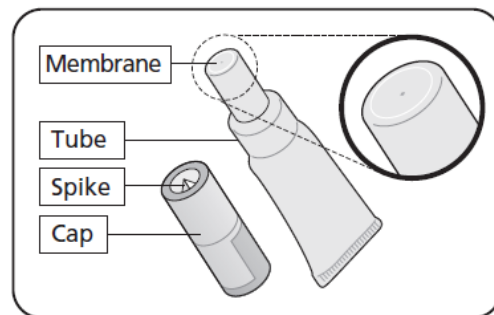

B Get the tube ready

1. Pull off the cap

- Keep the cap – you need this to pierce the membrane.
- Hold the tube upright.

2. Repeatedly flick the top of the tube until it is clear of any liquid

- Clear any liquid from the thinnest section of the tube by flicking just below the membrane.

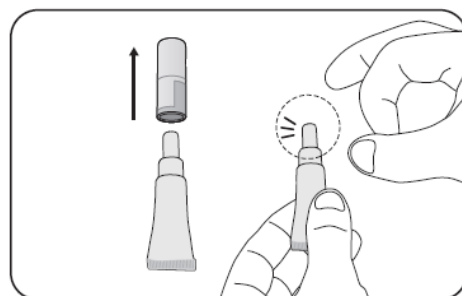

3. Position the cap to open the tube

- Keep the tube held upright.
- Hold the side of tube
- There is a small spike inside the top of the cap - in the centre.
- Turn the cap upside down (180°).

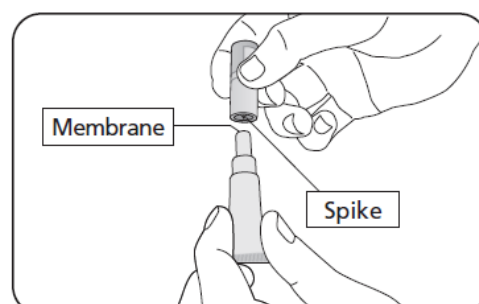

4. To open the tube

- You do not need to twist. Press the cap down to pierce the membrane.
- Then lift off the cap.

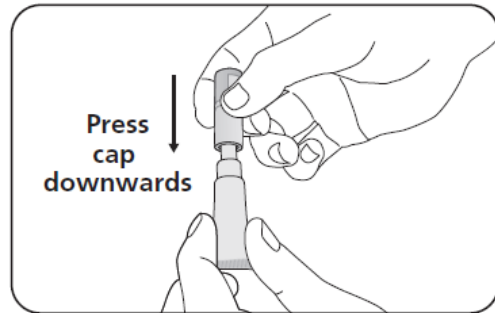

C Check the tube has opened correctly

1. Check the membrane has been pierced

- There should be a hole at the top of the tube.

2. What to do if the membrane has not been pierced

- If the membrane has not been pierced return to section B and repeat steps 2, 3 and 4.

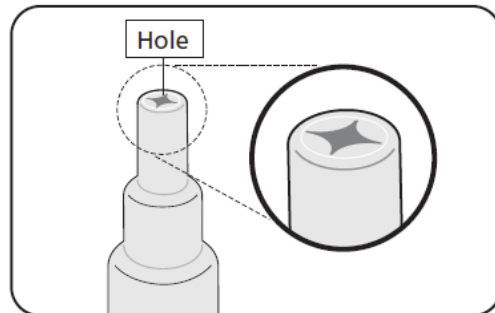

D Give the vaccine

- Once the tube is open check the liquid is clear, without any particles in it.
If you notice anything abnormal, do not use the vaccine.
- Give the vaccine straight away.

1. Position the child to give the vaccine

- Seat the child leaning slightly backwards.

2. Administer the vaccine

- Squeeze the liquid gently into the side of the child's mouth - towards the inside of their cheek.
- You may need to squeeze the tube a few times to get all of the vaccine out - it is okay if a drop remains in the tip of the tube.

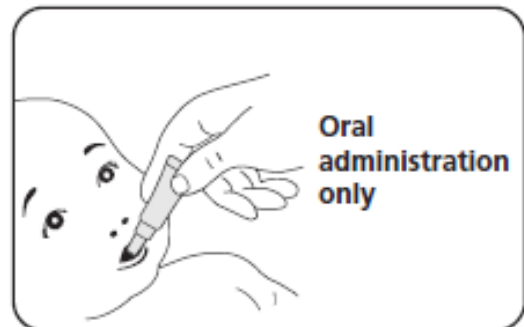

Trade marks are owned by or licensed to the GSK group of companies.

Version number: GDS017/IPI013/ Date of issue: 14/10/2019

©[year] GSK group of companies or its licensor

Manufacturer:

GlaxoSmithKline Biologicals s.a.
89, rue de l'Institut - 1330 Rixensart
Belgium

Tel: (32) 2 656 81 11 Fax: (32) 2 656 80 00

LABELLING

PARTICULARS TO APPEAR ON THE CARTON**SPIKE TUBE****TRADE NAME OF THE VACCINE**

Rotarix

COMMON NAME

Rotavirus vaccine

PHARMACEUTICAL FORM**Oral suspension****TARGET GROUP****Pediatric use****ROUTE OF ADMINISTRATION****Oral use**

Do not inject

NUMBER OF DOSES**1 dose (1.5 ml)****10 x 1 dose (1.5 ml)****50 x 1 dose (1.5 ml)****DESCRIPTION OF PRESENTATION**

1 tube

10 tubes (1 dose)

50 tubes (1 dose)

VACCINE COMPOSITION

1 dose (1.5 ml) contains:

Live attenuated human rotavirus RIX4414 strain: not less than $10^{6.0}$ CCID₅₀

Excipients: sucrose, di-sodium adipate, Dulbecco's Modified Eagle Medium (DMEM), sterile water

STORAGE CONDITIONS

Storage: 2°C - 8°C

Do not freeze

Protect from light

USE AND HANDLING INSTRUCTIONS



FOR ORAL USE ONLY

Refer to leaflet for complete instructions on use and handling.

LEGAL MENTIONS

Medicinal product subject to medicinal prescription
Keep out of the sight and reach of children
Read the package leaflet before use

COMPLETE NAME AND ADDRESS OF THE MANUFACTURER RESPONSIBLE FOR BATCH RELEASE

GlaxoSmithKline Biologicals s.a.
Rue de l'Institut 89
B-1330 Rixensart, Belgium

COPYRIGHT STATEMENT

©[year] GSK or licensor

REFERENCE TO THE BATCH NUMBER, MANUFACTURING DATE AND EXPIRY DATE

LOT/MFD/EXP:

TRADE MARK PROTECTION

Trade marks owned or licensed by GSK

**PARTICULARS TO APPEAR ON IMMEDIATE PACKAGING COMPONENTS
(LABEL)
SPIKE TUBE**

TRADE NAME OF THE VACCINE

Rotarix

NUMBER OF DOSES

1 dose (1.5 ml)

PHARMACEUTICAL FORM

Oral suspension

COMMON NAME

Rotavirus vaccine

ROUTE OF ADMINISTRATION

Oral use

STORAGE CONDITIONS

Storage: 2°C - 8°C
Do not freeze

**REFERENCE TO THE BATCH NUMBER, < MANUFACTURING DATE> AND
EXPIRY DATE**

Lot:
Exp:

**NAME (+ CITY AND COUNTRY) OF MANUFACTURER RESPONSIBLE FOR
BATCH RELEASE**

GSK Biologicals s.a. Rixensart - Belgium